

PPPL Researchers Develop Anti-terrorism Device

Anti-terrorism efforts may get a boost from the U.S. Department of Energy's Princeton Plasma Physics Laboratory (PPPL). A team led by PPPL engineer Charles Gentile is developing a Miniature Integrated Nuclear Detection System, called MINDS, which would have applications in transportation and site security. It would be used to scan moving vehicles, luggage, cargo vessels, and the like for specific nuclear signatures associated with materials employed in radiological weapons. MINDS could be employed at workplace entrances, post offices, tollbooths, airports, commercial shipping ports, as well as in police cruisers, to detect the transportation of unauthorized nuclear materials.

MINDS, which combines many off-the-shelf components with specific nuclear detection software, is capable

of detecting X-rays, soft gammas, gammas, and neutrons. Radionuclides can be recognized and differentiated from one another since each has a distinctive energy signature or fingerprint. The system compares the energy spectrum of the detected radionuclide with the spectra of particular radiological materials that might be used in weapons.

A basic proof-of-principle system is currently operational, and researchers are continuing the development and field testing of the full system and associated software. Proof-of-principle demonstrations, attended by representatives of state and local government, industry, and Federal laboratories, have confirmed the system's ability to detect and identify small amounts of nuclear material inside an inter-modal shipping container, and tests on detecting materials in moving vehicles are underway.

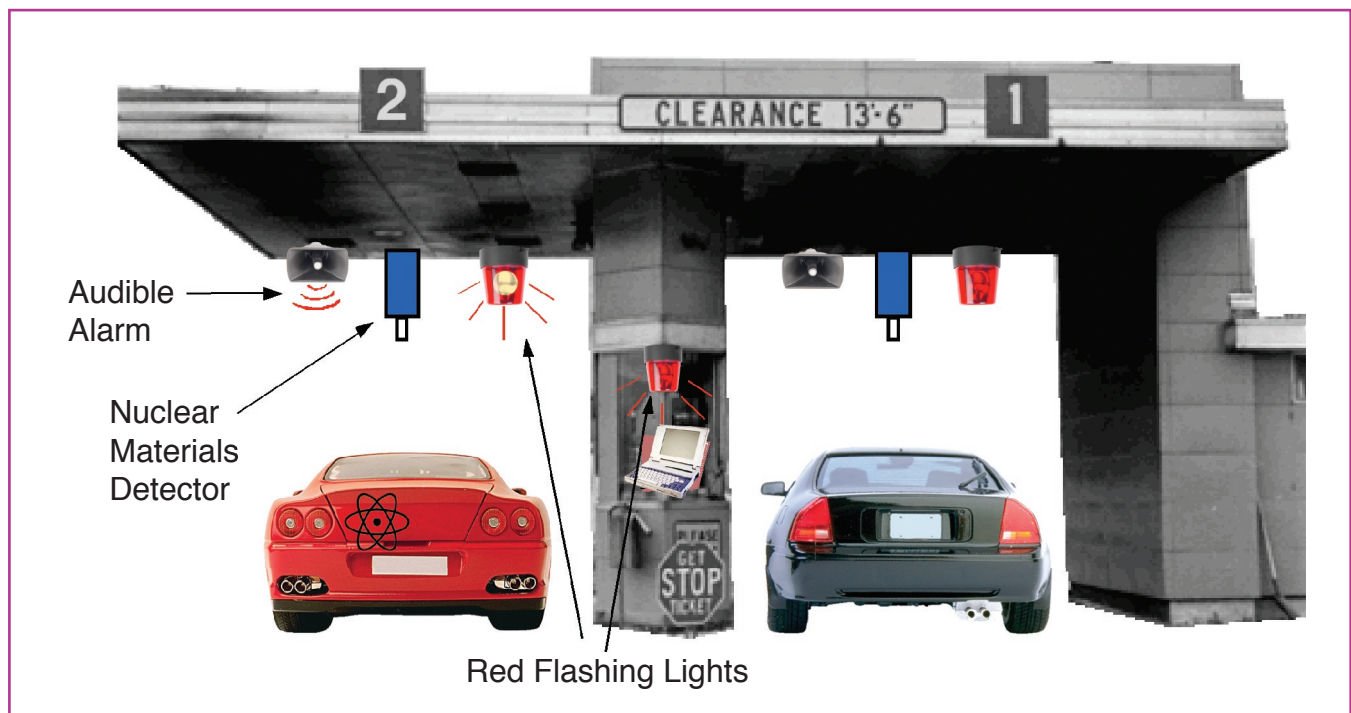

MINDS tollbooth application.

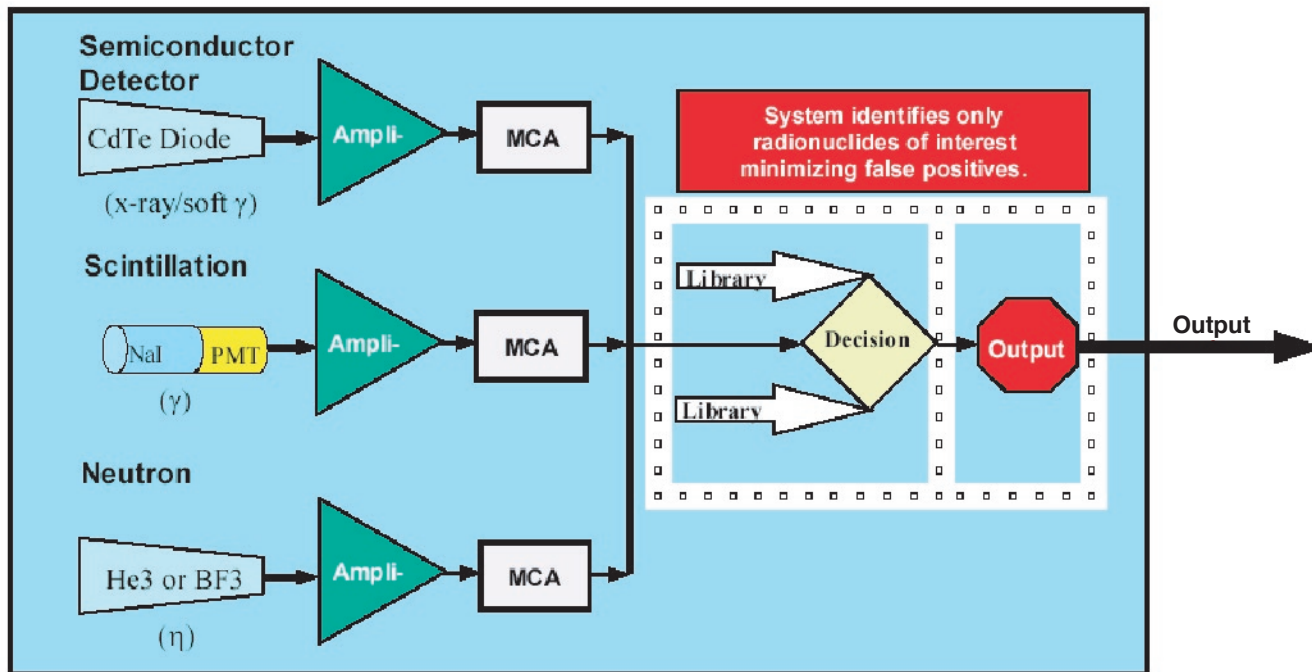

Main components of PPPL's Miniature Integrated Nuclear Detection System (MINDS). MCA: Multi-channel Analyser, PMT: Photo Multiplier Tube.

The System

MINDS includes a lap-top computer that stores databases of radionuclides for comparison, proprietary detection software (described below), and three different radiation detectors, or heads, to cover a whole gamut of nuclear signatures. The detector heads can include, for example, a boron trifluoride (BF₃) or helium (3He) tube to detect neutrons; a PIN diode or a Cadmium Zinc Telluride detector to detect X-rays and low-energy gamma rays; and a sodium iodide (NaI) crystal to detect higher energy gamma rays.

MINDS would typically be able to detect radiation (dependent on source quantity) from several feet away and would identify the type of radiation, but not the quantity. The system could be configured with one, two, or more heads to suit the needs of law enforcement and Homeland Security officials. For instance, airport officials might be interested in detecting materials such as cobalt or cesium that could be used in a “dirty” bomb. At tollbooths or in police cruisers, the system would be tuned to recognize but not sound an alarm for radioactive materials with legal uses such as medical radioisotopes. MINDS also would be able to detect some shielded materials since shielding often results in the generation of X-rays of certain energies.

Once a unit is in place, law enforcement agencies would incorporate it into an alerting system. For example, it could be set up at a tollbooth so that when a suspicious vehicle is detected, a picture would be taken, and an e-mail or wireless alert would be sent to authorities. The vehicle could then be stopped a short distance beyond the tollbooth.

Partners in MINDS' Development

In addition to PPPL, the Rutgers University Center for Advanced Information Processing (CAIP) and Picatinny Arsenal are supporting the MINDS development effort.

Rutgers University

MINDS must be programmed to respond only to signatures of threat-specific radionuclides, greatly minimizing false positive alarms, which would result from the transportation of approved radionuclides such as medical and industrial shipments. Furthermore, signal losses due to distance, shielding and other absorbers, as well as noise due to background radiation, complicate material classification. For example, terrorists might attempt to hide weapons materials by shielding them or transporting

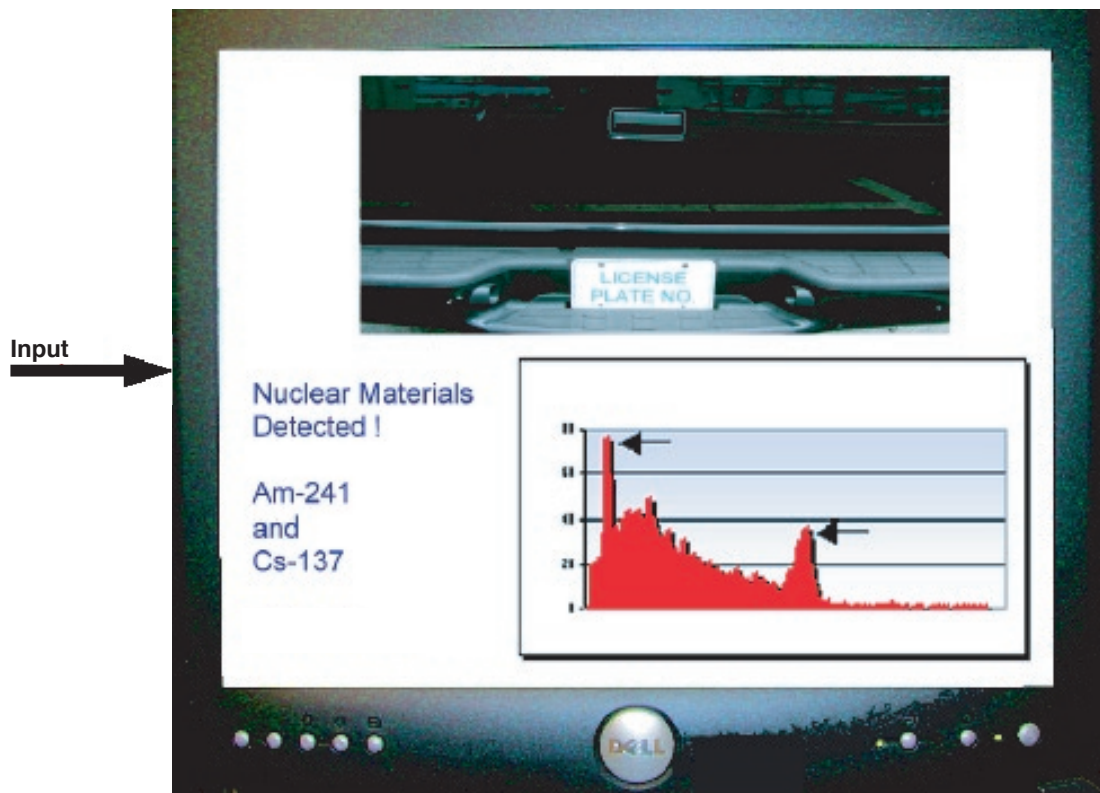

them with legal radioisotopes. To overcome these difficulties, the PPPL team, in collaboration with the Center for Advanced Information Processing (CAIP) at Rutgers University, is combining a library of specific spectra with CAIP's advanced neural-network-based detection software, known as the Vigilant Decision Machine (VDM).

The VDM software engine has been proven to detect rare events amidst complex signals found in real-world environments. For example, VDM has been used at airports in conjunction with a coherent X-ray scattering technique to successfully screen luggage for plastic explosives. It has also been used in voice and face recognition systems and in defense-related applications.

In MINDS, VDM will be used for pattern recognition. The software is capable of learning the specific signals associated with various radionuclides and distinguishing those signatures from background noise and other interference. CAIP will apply VDM's sophisticated software to the MINDS energy spectra so that they are fine-tuned to the subtle differences between radioactive materials, dangerous and benign. The software will also improve MINDS' ability to detect radionuclides at a distance through walls and other absorbers, and in the presence of electronic noise. PPPL and Rutgers have jointly submitted several funding support proposals for continued development.

Picatiny Arsenal

Picatiny Arsenal, a U.S. Army facility currently serving as an antiterrorism training center, is providing PPPL with funding for the further development of MINDS. In Fiscal Year 2002, this funding was used to prepare for successful demonstrations of the system's ability to detect nuclear material inside an automobile moving through the PPPL security gate — an analog to the tollbooth application. MINDS detection hardware has been located at the PPPL guard gate with readouts at a remote location in the Laboratory's Lyman Spitzer Office Building.

During Fiscal Year 2003, Picatiny funding is supporting the full integration of the PIN diode (and/or Cadmium Zinc Telluride or Cadmium Telluride) and gamma ray detectors into the system, building upon previous work. Work is continuing on the adaptation of CAIP's VDM system for pattern recognition, as well as the development of software for the distinction of X-rays generated by the interaction of nuclear radiation with shielding materials. This allows MINDS to detect and identify nuclear materials despite shielding.

Another area being addressed is the compatibility of outputs from the MINDS system with other nuclear detection systems.

Future Development Efforts

Tasks required for the full development of MINDS include:

- The continued compilation of a database of signal waveforms for nuclear materials.
- The optimization of MINDS' ability to distinguish unauthorized from authorized materials (even when they are mixed together), and at the same time maximizing the ability to detect which unauthorized materials are present.
- Understanding the interplay between the various parameters affecting signal-to-noise ratio (e.g., distance from the sensors, quantity of materials, degree of shielding, absorption from surrounding materials, and external noise) to develop the signal preprocessing that will provide robust performance for a cycle time of less than one second. This will involve the continued work on the adaptation of CAIP's VDM software as necessary to meet speed and recognition accuracy requirements.
- Integration of a neutron detector into the system.
- The development of a cohesive package for the system that will address portability and environmental issues.
- The field testing of the prototype system in various implementations, configurations, and environments. Authorities have expressed interest in field testing the system at Port Elizabeth and at bridge/tunnel entrances. Such interest has also been expressed by Amtrak police and by Picatinny Arsenal for their homeland defense training facility. Field tests will require installing systems and collecting data over a period of time to determine the background radiation for specific sites in addition to other background signals, so that baselines can be established.

10 mph Driveby with 28 mCi Am-241 (unshielded) and 4.1 mCi Cs-137 in Lead (Both in trunk of car)

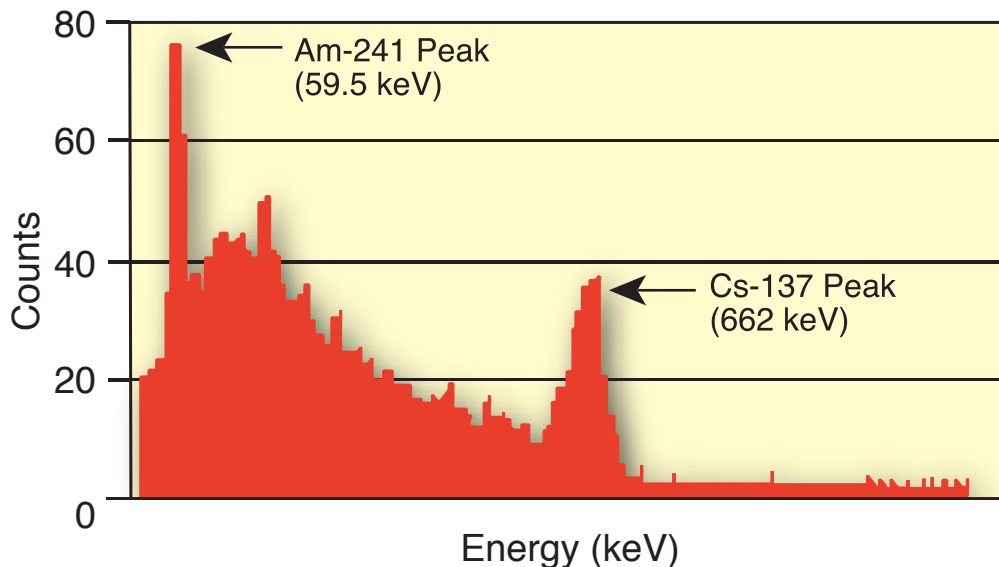

Energy footprint showing the presence of the radionuclides Americium and Cesium.

This technology is available for licensing from Princeton University. Interested parties please contact: Mr. Lewis Meixler, Head of Applications Research and Technology Transfer, Princeton Plasma Physics Laboratory, 609-243-3009, or lmeixler@pppl.gov.

For additional information, please contact: Information Services, Princeton Plasma Physics Laboratory, P.O. Box 451, Princeton, NJ 08543, 609-243-2750.

The Princeton Plasma Physics Laboratory is a United States Department of Energy Facility engaged in the development of magnetic fusion energy. It is funded by the US Department of Energy (DOE) under contract DE-AC02-76CHO3073.
